

# MR14-25

Reach Truck | 1400 - 2500kg



[www.yale.com](http://www.yale.com)

**Yale**   
People. Products. Productivity.™

## About Yale®

The MR series is the next level in reach truck productivity, delivered through innovation, technology and ergonomic design.

As your customers demand more from you, you should be able to expect more from your reach trucks. With over 80 years in the material handling industry, the Yale MR series delivers on this promise and features even more benefits than before including:

- Innovative technology including laser positioning, dual CANbus technology, 'get home' function and touch screen display
- Flexibility with seven models in capacities from 1400kg to 2500kg and lift heights up to 12.65m
- Three chassis available to match your application
- Productivity with higher travel, lift and lower speeds
- Operator comfort with unique ergonomic controls and enhanced visibility
- Greater efficiency with easier serviceability and lower costs of ownership
- Aftermarket service and support

Support for the Yale MR series Reach Trucks can be found throughout the Asia-Pacific region – provided by a big regional footprint stretching from Australia and New Zealand, on through Singapore, Malaysia, Indonesia, Thailand, South Korea, Taiwan, Vietnam and the Philippines.

For more information please contact your local dealer.

### ▶ Laser Positioning\*

The laser projects a red dot and line from the location on the fork carriage, enabling the operator to clearly see where the forks need to be positioned to lift the pallet securely. The laser is automatically switched on when the mast lifts beyond free lift (around 2m).



### ▶ Ergonomic Controls\*

The joystick matches the natural handgrip of the operator, providing easy access for all lift functions, forward/reverse, and the horn. The AccuTouch mini-lever module with built-in controls maximises operator familiarity, while additional function buttons are integrated into the adjustable armrest.



### ▶ Premium Display\*

Industry first premium touch screen display allows operators to be in full control of the truck at all times. The display provides PIN access, height preselect, fleet management information, weight indication, lift interrupt override and creep speed.



### ▶ Advanced Diagnostics

A single plug-in service point connects your engineer's laptop to our advanced truck diagnostics, giving them instant access to essential service information. On-board, the unique dual integrated CANbus technology ensures fast identification of faults while the operator's display also provides critical status of components and error codes.

## MR14-25 Reach Truck Features

### ▶ Cold Store Cabin\*

A drop in temperatures doesn't mean a drop in performance. The fully insulated cabin is available in both standard and narrow chassis models. Heated windows and heaters built into the cabin doors maintain the optimum temperature for the operator.



### ▶ Overhead Guard

Four different drive-in racking overhead guards are available to meet various application requirements.



### ▶ More Fuel-Efficiency

The ECO-eLo energy efficiency mode can, depending on the application, reduce energy consumption by up to 20% without having a significant negative effect on overall productivity.

### ▶ Quick-Change Battery\*

The side extraction system enables rapid battery changeover to maximise uptime and make battery changeover as easy as possible.



### ▶ Intelligent Technology

Integrated Dual CANbus technology ensures you will be able to identify an error or malfunction and fix it fast. Our unique innovative 'Get Home' function can even be activated after all functions come to rest, allowing the operator to drive the truck to an appropriate place of repair.

### ▶ Easy Access Service Areas

Easy access to motors, hydraulics and other components including a single plug-in access point for diagnostics.



# Mechanical Specifications

		YALE			
		MR14	MR16		
Distinguishing Mark	1.1	MANUFACTURER			
	1.2	Manufacturer's type designation			
	1.3	Drive: electric (battery or mains), diesel, petrol, fuel gas			
	1.4	Operator type: hand, pedestrian, standing, seated, order-picker			
Weights	1.5	Rated capacity/rated load	Q (kg)	1400	1600
	1.6	Load centre distance	c (mm)	600	600
	1.8	Load distance, centre of drive axle to fork	x (mm)	402	452
	1.9	Wheelbase	y (mm)	1400	1450
	2.1	Service weight	kg	3112	3162
Tyre/Chassis	2.2	Axle loading, laden front/rear <sup>(6)</sup>	kg	1977/1135	2018/1144
	2.4	Axle loading, fork advanced, laden front/rear	kg	682/3830	601/4162
	2.5	Axle loading, fork retracted, unladen front/rear	kg	1778/2735	1853/2909
	3.1	Tyres: polyurethane, tophane, vulkollan, front/rear	Vulkollan/Vulkollan	Vulkollan/Vulkollan	
	3.2	Tyre size, front	ø mm x mm	343x140	343x140
Dimensions	3.3	Tyre size, rear	ø mm x mm	285x100	285x100
	3.5	Wheels, number front/rear (x = driven wheels)		1x/2	1x/2
	3.7	Tread, rear	b <sub>11</sub> (mm)	1155	1155
	4.1	Tilt of mast/fork carriage forward/backward	α/β (°)	2/4	2/4
	4.2	Height of mast, lowered	h <sub>1</sub> (mm)	2195	2195
	4.3	Free lift	h <sub>2</sub> (mm)	1648	1648
	4.4	Lift	h <sub>3</sub> (mm)	5000	5000
	4.5	Height, mast extended <sup>(1)</sup>	h <sub>4</sub> (mm)	5563	5563
	4.7	Height of overhead guard (cabin) <sup>(2)</sup>	h <sub>6</sub> (mm)	2175	2175
	4.8	Seat height/stand height	h <sub>7</sub> (mm)	1082	1082
	4.10	Height of wheel arms	h <sub>9</sub> (mm)	308	308
	4.19	Overall length	l <sub>1</sub> (mm)	2379	2379
	4.20	Length to face of forks	l <sub>2</sub> (mm)	1229	1229
	4.21	Overall width <sup>(3)</sup>	b <sub>1</sub> /b <sub>2</sub> (mm)	1265	1265
	4.22	Fork dimensions ISO2331	s/e/l (mm)	40/80/1150	40/120/1150
	4.23	Fork carriage ISO 2328, class/type A,B		2A	2A
	4.24	Fork carriage width	b <sub>3</sub> (mm)	700	700
	4.25	Distance between fork-arms, min./max. <sup>(4)</sup>	b <sub>5</sub> (mm)	220/640	260/680
	4.26	Distance between wheel arms/loading surfaces	b <sub>4</sub> (mm)	900	900
	4.28	Reach distance	l <sub>4</sub> (mm)	585	635
	4.31	Ground clearance, laden, below mast	m <sub>1</sub> (mm)	75	75
	4.32	Ground clearance, centre of wheelbase	m <sub>2</sub> (mm)	75	75
	4.34.1	Aisle width for pallets 1000mm x 1200mm crossways	Ast (mm)	2718	2731
	4.34.2	Aisle width for pallets 800mm x 1200mm lengthways	Ast (mm)	2764	2767
	4.35	Turning radius	Wa (mm)	1671	1718
	4.37	Length across load arms	l7 (mm)	1795	1845
	4.43	Step height	(mm)	371	371
Performance Data	5.1	Travel speed, laden/unladen <sup>(7)</sup>	km/h	11/11 (14/14)	11/11 (14/14)
	5.1.1	Travel speed, laden/unladen, backwards <sup>(7)</sup>	km/h	11/11 (14/14)	11/11 (14/14)
	5.2	Lift speed, laden/unladen	m/s	0.37/0.63 (0.47/0.73)	0.32/0.63 (0.42/0.73)
	5.3	Lowering speed, laden/unladen	m/s	0.55/0.55	0.55/0.55
	5.4	Reaching speed, laden/unladen	m/s	0.15/0.15	0.15/0.15
	5.7	Gradeability laden/unladen	%	12/15	11/15
	5.8	Max gradeability laden/unladen	%	12/15	12/15
	5.9	Acceleration time laden/unladen	s	On request	On request
	5.10	Service brake		Electric	Electric
	Electric-engine	6.1	Drive motor rating S2 60 min	kW	6.4
6.2		Lift motor rating at S3 15%	kW	14	14
6.3		Battery according to DIN 43531/35/36 A, B, C, no		C	C
6.4		Battery voltage/nominal capacity K <sub>5</sub>	(V)/(Ah)	48/420 <sup>(8)</sup>	48/420 <sup>(8)</sup>
6.5		Battery weight <sup>(4)</sup>	kg	750	750
6.6		Energy consumption according to VDI cycle	kWh/h at number of cycles	On request	On request
Additional Data	8.1	Type of drive unit		AC	AC
	10.1	Operating pressure for attachments	bar	180	180
	10.2	Oil volume for attachments	l/min	20	20
	10.7	Sound pressure level at the driver's seat	dB(A)	<69.7	<69.7

<sup>(1)</sup> With load backrest h4 + 508mm MR14-MR16-MR16N-MR16HD, + 443mm MR20-MR25-MR20HD.

<sup>(2)</sup> With beacon h6 + 120mm. ; With OHG Grid Protector h6 + 20mm ; With OHG Screen Protector h6 + 30mm.

<sup>(3)</sup> With load wheels lateral covers: 1289mm MR14-MR16-MR20-MR16HD, 1153mm (MR16N), 1373mm (MR25-MR20HD).

<sup>(4)</sup> These values may vary of +/- 5%.

<sup>(5)</sup> Forks retracted.

		YALE				
		MR16N	MR16HD	MR20	MR20HD	MR25
Distinguishing Mark		Electric (Battery)				
		Seated				
		1600	1600	2000	2000	2500
		600	600	600	600	600
		382	308	430	353	503
Weights		1450	1450	1500	1500	1650
		3111	4038	3615	4425	4038
		1922/1189	2417/1621	2261/1354	2567/1858	2520/1518
		569/4142	883/4755	671/4943	891/5534	773/5765
		1680/3032	2172/3466	2032/3583	2235/4189	2371/4167
Tyre/Chassis		Vulkollan/Vulkollan				
		343x140	343x140	343x140	343x140	343x140
		285x100	285x100	285x100	285x140	285x140
		1x/2	1x/2	1x/2	1x/2	1x/2
		1025	1155	1155	1195	1195
Dimensions		2/4	2/4	2/4	2/4	2/4
		2195	3227	2195	3227	2195
		1648	2680	1582	2614	1582
		5000	8050	4650	7900	4650
		5563	8613	5263	8513	5263
		2175	2175	2175	2175	2175
		1082	1082	1082	1082	1082
		308	308	308	308	308
		2449	2523	2451	2528	2528
		1299	1373	1301	1378	1378
		1125	1265	1265	1345	1345
		40/120/1150	40/120/1150	40/120/1150	45/120/1150	45/120/1150
		2A	2A	2A	2A	2A
		700	700	700	700	700
		260/680	260/680	260/680	260/680	260/680
		795	900	900	900	900
		565	491	613	536	686
		75	65	65	65	65
		75	65	65	65	65
		2762	2834	2795	2850	2890
		2811	2896	2835	2904	2915
		1700	1718	1767	1767	1911
		1845	1845	1895	1895	2045
		371	371	371	371	371
		11/11 (14/14)	14/14	14/14	14/14	14/14
		11/11 (14/14)	14/14	14/14	14/14	14/14
		0.32/0.63 (0.42/0.73)	0.42/0.73	0.37/0.64	0.37/0.68	0.30/0.64
	0.55/0.55	0.55/0.55	0.55/0.50	0.55/0.55	0.55/0.50	
	0.15/0.15	0.15/0.15	0.15/0.15	0.15/0.15	0.15/0.15	
	11/15	10/14	10/15	8/13	8/14	
	12/15	12/15	12/15	12/15	12/15	
	On request	On request	On request	On request	On request	
	Electric	Electric	Electric	Electric	Electric	
	6.4	6.4	6.4	6.4	6.4	
	14	14	14	14	14	
	C	C	C	C	C	
	48/420 <sup>(8)</sup>	48/700 <sup>(8)</sup>	48/560 <sup>(8)</sup>	48/700 <sup>(8)</sup>	48/700 <sup>(8)</sup>	
	750	939	939	1119	1119	
	On request	On request	On request	On request	On request	
	AC	AC	AC	AC	AC	
	180	180	180	180	180	
	20	20	20	20	20	
	<69.7	<69.7	<69.7	<69.7	<69.7	

<sup>(6)</sup> See Truck dimensions for batteries tables.

<sup>(7)</sup> Values in brackets are Optional.

<sup>(8)</sup> Sideshift distance on either side is + / -75mm on all trucks. Reduction of + / - 25mm on MR16N.

All values are nominal values and they are subject to tolerances. For further information, please contact the manufacturer. Yale products might be subject to change without notice. Lift trucks illustrated may feature optional equipment. Values may vary with alternative configurations.

# Standard Features & Options

Feature	MR14/16	MR16N	MR20/25	MR16HD	MR20HD
Intermediate step	■	■	■	■	■
Grab handle on overhead guard post	■	■	■	■	■
Grab handle under armrest	■	■	■	■	■
AccuTouch mini-levers mounted on adjustable length armrest	■	■	■	■	■
Joystick mounted on adjustable length armrest	○	○	○	○	○
Full suspension seat - 60mm suspension travel cloth upholstery	■	■	■	■	■
Full suspension seat - 80mm suspension travel cloth upholstery	○	○	○	○	○
Headrest (cloth version only)	○	○	○	○	○
Synchronised seat cushion and backrest movement (cloth version only)	○	○	○	○	○
Seat belt	○	○	○	○	○
Heated seat	○	○	○	○	○
Antistatic seat (cloth version only)	○	○	○	○	○
Vinyl seat upholstery	○	○	○	○	○
Standard display	■	■	■	■	■
Premium display with touch screen	○	○	○	○	○
Keyless access	○	○	○	○	○
Adjustable steering column	■	■	■	■	■
Automatic park brake Yalestop	■	■	■	■	■
180° steering	■	■	■	■	■
360° steering	○	○	○	○	○
Driver select steering mode 180/360° (push button)	○	○	○	○	○
Travel speed 11km/h	■	■	+	+	+
Travel speed 14km/h with electric load wheel braking	○	○	■	■	■
Speed slow down mast reached forward	■	■	■	■	■
Speed slow down on cornering	■	■	■	■	■
Speed slow down over free lift	■	■	■	■	■
3 stage mast / tilting carriage	■	■	■	■	■
Simultaneous lift / reach functionality	■	■	■	■	■
Simultaneous hydraulic functionality - 3 functions	○	○	○	○	○
Mast cushioning over free lift/main lift sections - fixed sensor mounting	■	■	■	■	+
Lift Comfort package <sup>(1)</sup>	○	○	○	■	■
Lift Performance package	○	○	+	■	■
Laser line fork positioning aid (above free lift)	○	○	○	○	○
Auto side shift centring	○	○	○	○	○
Auto fork levelling in the horizontal position	○	○	○	○	○
Height preselector (with/without pallet detection device)	○	○	○	○	○
Fork mounted camera/monitor	○	○	○	○	○
Weight indicator	○	○	○	○	○
5th hydraulic function	○	○	○	○	○
Universal support bracket	○	○	○	○	○
Beverage holder and document tray	○	○	○	○	○
A4 clipboard	○	○	○	○	○
Stretch film roll holder	○	○	○	○	○
Lift limit with override (1 x height setting)	○	○	○	○	○
Lift limit with override (2 x height settings)	○	○	○	○	○
Lower limit (with override option)	○	○	○	○	○
Flashing beacon	○	○	○	○	○
Work lights x 2 (mast side)	○	○	○	○	○
Work lights x 1 (drive side)	○	○	○	○	○
Polycarbonate (lexan) protection on overhead guard	○	○	○	○	○
Metal grid protection on overhead guard	○	○	○	○	○
Top/front load wheel protection	■	■	■	■	■
Side load wheel protection	○	○	○	○	○
High temperature environment	○	○	○	○	○
Side battery change - rollers	○	○	○	○	○
Side battery change - tray	○	○	○	○	○
Extension cable	○	○	○	○	○
Drive-in overhead guard (w 930 x h 1400 / w 930 x h 1700mm)	○	○	○	○	○
Antistatic drive and load wheels	○	○	○	○	○
Wet surface drive and load wheels	○	○	○	○	○
Side guidance rollers	○	○	○ / ★	○	★
DC/DC converter (choice of 12V/48V, 24V/48V, 12-24V/48V options)	○	○	○	○	○
Audible alarm (choice of forks leading, forks trailing, both travel directions)	○	○	○	○	○
Load backrest (choice of heights 1000/1500mm)	○	○	○	○	○

<sup>(1)</sup> Includes; End of stroke slow down on lift. Soft stop on lowering. Height controlled mast cushioning over Free Lift/Main lift mast section. Height indicator.  
 ■ Standard ○ Optional + Not available ★ SPED

# Specifications

## Dimension Chart

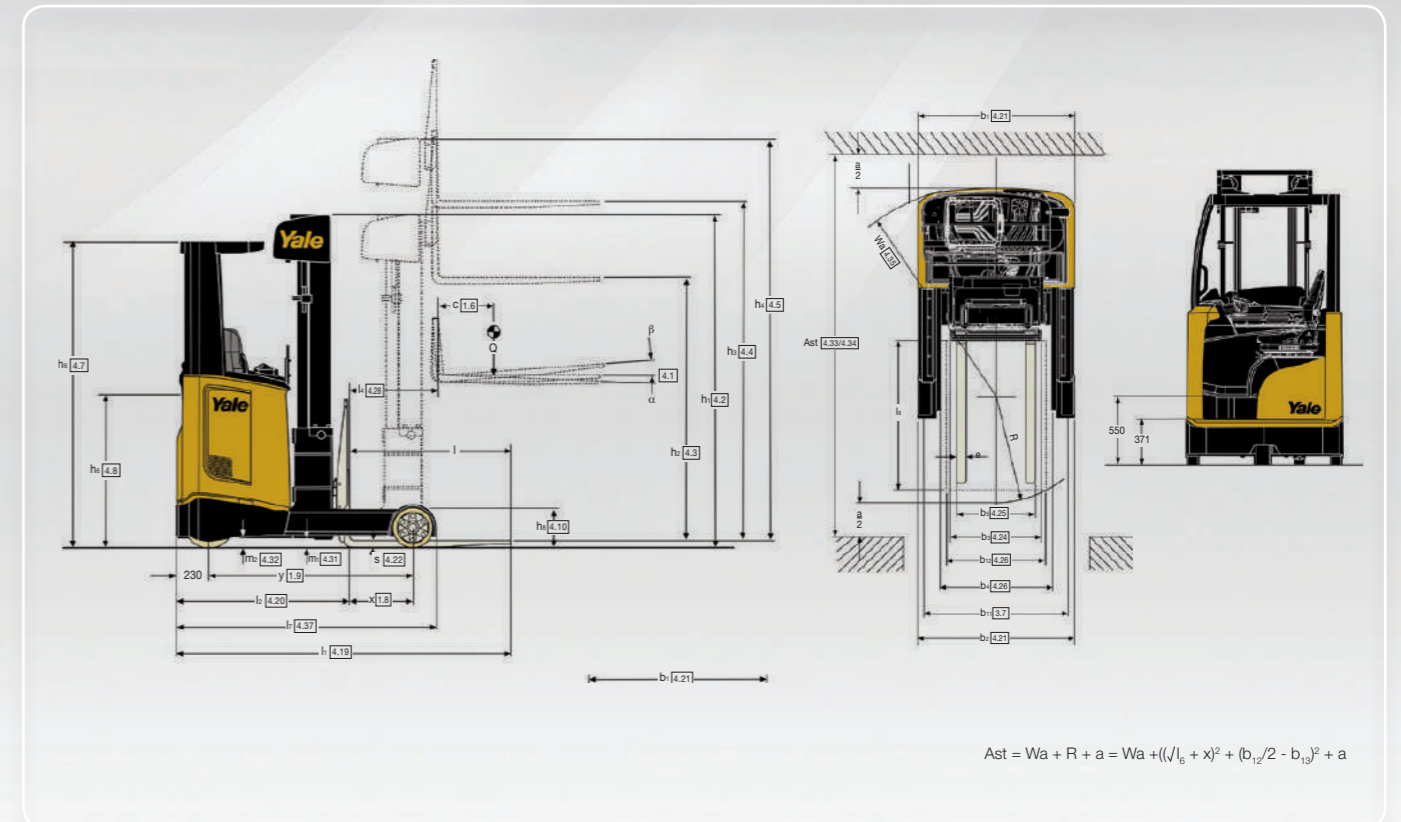

## Features

- 1 Touch screen technology**  
An industry first including PIN access, height pre-select, fleet management information, weight indication, lift interrupt override and creep speed selection.
- 2 New joystick**  
The joystick matches the natural handgrip of the operator.
- 3 Contoured arm rest**  
Provides support for the right arm and integrated raised palm rest.
- 4 Wider spaced floor pedals**  
Provide increased leg room.
- 5 Extensive floor space and pedal clearances**  
For easier on and off access.
- 6 New full suspension adjustable seat**  
With integral lumbar support reduces whole body vibration.
- 7 New steering column**  
Mounted directly on to the chassis with sturdy slider mechanism.
- 8 New steering wheel design**  
With soft touch and comfort grip knob. Provides a comfortable driving posture to alleviate build up of stress on the operators wrist, elbow and arm.



# Specifications

## Battery

### MR14 battery dimensions

Distinguishing Mark	Battery type		C "Super"	C	C "Super"	C	C "Super"	
	1.2	Manufacturer's type designation	<b>MR14</b>					
1.8	Load distance, centre of drive axle to fork	x (mm)	402	330	330	258	258	
1.9	Wheelbase	y (mm)	1400	1400	1400	1400	1400	
Weights	2.1	Service weight	kg	3112	3309	3320	3495	3541
	2.3	Axle loading, unladen front/rear <sup>(6)</sup>	kg	1977/1135	2025/1285	2032/1289	2055/1440	2084/1457
	2.4	Axle loading fork advanced, laden front/rear	kg	682/3830	792/3917	800/3921	885/4010	914/4027
2.5	Axle loading fork retracted, laden front/rear	kg	1778/2735	1753/2956	1760/2960	1711/3184	1741/3201	
Dimensions	4.19	Overall length	l <sub>1</sub> (mm)	2379	2451	2451	2523	2523
	4.20	Length to face of forks	l <sub>2</sub> (mm)	1229	1301	1301	1373	1373
	4.28	Reach distance	l <sub>4</sub> (mm)	585	513	513	441	441
	4.34.1	Aisle width for pallets 1000mm x 1200mm crossways	Ast (mm)	2718	2771	2771	2825	2826
	4.34.2	Aisle width for pallets 800mm x 1200mm lengthways	Ast (mm)	2764	2829	2829	2895	2895
4.35	Turning radius	Wa (mm)	1671	1671	1671	1671	1671	
Electric Engine	6.3	Battery according to DIN 43531/35/36 A, B, C, no	C "Super"	C	C "Super"	C	C "Super"	
	6.4	Battery voltage/nominal capacity K <sub>5</sub>	(V)/(Ah)	48/465	48/560	48/620	48/700	48/775
	6.5	Battery weight <sup>(4)</sup>	kg	750	939	950	1119	1165

### MR16 battery dimensions

Distinguishing Mark	Battery type		C "Super"	C	C "Super"	C	C "Super"	
	1.2	Manufacturer's type designation	<b>MR16</b>					
1.8	Load distance, centre of drive axle to fork	x (mm)	452	380	380	308	308	
1.9	Wheelbase	y (mm)	1450	1450	1450	1450	1450	
Weights	2.1	Service weight	kg	3162	3360	3371	3546	3592
	2.3	Axle loading, unladen front/rear <sup>(6)</sup>	kg	2018/1144	2069/1291	2077/1294	2103/1443	2133/1459
	2.4	Axle loading fork advanced, laden front/rear	kg	601/4162	714/4246	721/4250	810/4336	839/4352
2.5	Axle loading fork retracted, laden front/rear	kg	1853/2909	1825/3135	1832/3139	1779/3367	1809/3383	
Dimensions	4.19	Overall length	l <sub>1</sub> (mm)	2379	2451	2451	2523	2523
	4.20	Length to face of forks	l <sub>2</sub> (mm)	1229	1301	1301	1373	1373
	4.28	Reach distance	l <sub>4</sub> (mm)	635	563	563	491	491
	4.34.1	Aisle width for pallets 1000mm x 1200mm crossways	Ast (mm)	2731	2781	2781	2834	2834
	4.34.2	Aisle width for pallets 800mm x 1200mm lengthways	Ast (mm)	2767	2830	2830	2896	2896
4.35	Turning radius	Wa (mm)	1718	1718	1718	1718	1718	
Electric Engine	6.3	Battery according to DIN 43531/35/36 A, B, C, no	C "Super"	C	C "Super"	C	C "Super"	
	6.4	Battery voltage/nominal capacity K <sub>5</sub>	(V)/(Ah)	48/465	48/560	48/620	48/700	48/775
	6.5	Battery weight <sup>(4)</sup>	kg	750	939	950	1119	1165

### MR16N battery dimensions

Distinguishing Mark	Battery type		B "Super"	B	B "Super"	B	B "Super"	
	1.2	Manufacturer's type designation	<b>MR16N</b>					
1.8	Load distance, centre of drive axle to fork	x (mm)	382	292	292	202	202	
1.9	Wheelbase	y (mm)	1450	1450	1450	1450	1450	
Weights	2.1	Service weight	kg	3115	3309	3317	3498	3514
	2.3	Axle loading, unladen front/rear <sup>(6)</sup>	kg	1924/1191	1947/1362	1952/1365	1955/1543	1965/1549
	2.4	Axle loading fork advanced, laden front/rear	kg	572/4143	672/4237	677/4240	757/4341	766/4347
2.5	Axle loading fork retracted, laden front/rear	kg	1682/3033	1606/3303	1611/3306	1514/3584	1524/3590	
Dimensions	4.19	Overall length	l <sub>1</sub> (mm)	2449	2539	2539	2629	2629
	4.20	Length to face of forks	l <sub>2</sub> (mm)	1299	1389	1389	1479	1479
	4.28	Reach distance	l <sub>4</sub> (mm)	565	475	475	385	385
	4.34.1	Aisle width for pallets 1000mm x 1200mm crossways	Ast (mm)	2762	2828	2828	2898	2899
	4.34.2	Aisle width for pallets 800mm x 1200mm lengthways	Ast (mm)	2811	2893	2893	2976	2976
4.35	Turning radius	Wa (mm)	1700	1700	1700	1700	1700	
Electric Engine	6.3	Battery according to DIN 43531/35/36 A, B, C, no	B "Super"	B	B "Super"	B	B "Super"	
	6.4	Battery voltage/nominal capacity K <sub>5</sub>	(V)/(Ah)	48/465	48/560	48/620	48/700	48/775
	6.5	Battery weight <sup>(4)</sup>	kg	750	937	945	1119	1135

# Specifications

## Battery

### MR20 battery dimensions

Distinguishing Mark	Battery type		C "Super"	C	C "Super"	
	1.2	Manufacturer's type designation	<b>MR20</b>			
1.8	Load distance, centre of drive axle to fork	x (mm)	430	358	358	
1.9	Wheelbase	y (mm)	1500	1500	1500	
Weights	2.1	Service weight	kg	3626	3801	3847
	2.3	Axle loading, unladen front/rear <sup>(6)</sup>	kg	2268/1358	2296/1504	2326/1520
	2.4	Axle loading fork advanced, laden front/rear	kg	679/4947	770/5030	801/5046
2.5	Axle loading fork retracted, laden front/rear	kg	2039/3586	1971/3829	2002/3845	
Dimensions	4.19	Overall length	l <sub>1</sub> (mm)	2451	2523	2523
	4.20	Length to face of forks	l <sub>2</sub> (mm)	1301	1373	1373
	4.28	Reach distance	l <sub>4</sub> (mm)	613	541	541
	4.34.1	Aisle width for pallets 1000mm x 1200mm crossways	Ast (mm)	2795	2846	2846
	4.34.2	Aisle width for pallets 800mm x 1200mm lengthways	Ast (mm)	2835	2900	2900
4.35	Turning radius	Wa (mm)	1767	1767	1767	
Electric Engine	6.3	Battery according to DIN 43531/35/36 A, B, C, no	C "Super"	C	C "Super"	
	6.4	Battery voltage/nominal capacity K <sub>5</sub>	(V)/(Ah)	48/620	48/700	48/775
	6.5	Battery weight <sup>(4)</sup>	kg	950	1119	1165

### MR25 battery dimensions

Distinguishing Mark	Battery type		C "Super"	C	C "Super"	
	1.2	Manufacturer's type designation	<b>MR25</b>			
1.8	Load distance, centre of drive axle to fork	x (mm)	503	431	431	
1.9	Wheelbase	y (mm)	1650	1650	1650	
Weights	2.1	Service weight	kg	4084	4230	4292
	2.3	Axle loading, unladen front/rear <sup>(6)</sup>	kg	2552/1532	2565/1665	2606/1686
	2.4	Axle loading fork advanced, laden front/rear	kg	804/5780	876/5855	917/5875
2.5	Axle loading fork retracted, laden front/rear	kg	2402/4182	2306/4424	2348/4444	
Dimensions	4.19	Overall length	l <sub>1</sub> (mm)	2528	2600	2600
	4.20	Length to face of forks	l <sub>2</sub> (mm)	1378	1450	1450
	4.28	Reach distance	l <sub>4</sub> (mm)	686	614	614
	4.34.1	Aisle width for pallets 1000mm x 1200mm crossways	Ast (mm)	2890	2938	2938
	4.34.2	Aisle width for pallets 800mm x 1200mm lengthways	Ast (mm)	2915	2978	2978
4.35	Turning radius	Wa (mm)	1911	1911	1911	
Electric Engine	6.3	Battery according to DIN 43531/35/36 A, B, C, no	C "Super"	C	C "Super"	
	6.4	Battery voltage/nominal capacity K <sub>5</sub>	(V)/(Ah)	48/775	48/840	48/930
	6.5	Battery weight <sup>(4)</sup>	kg	1165	1306	1368

### MR16HD and MR20HD battery dimensions

Distinguishing Mark	Battery type		C "Super"	C	C "Super"	C "Super"	C	C "Super"	
	1.2	Manufacturer's type designation	<b>MR16HD</b>		<b>MR20HD</b>				
1.8	Load distance, centre of drive axle to fork	x (mm)	308	308	308	353	281	281	
1.9	Wheelbase	y (mm)	1450	1450	1450	1500	1500	1500	
Weights	2.1	Service weight	kg	4049	4224	4270	4471	4617	4679
	2.3	Axle loading, unladen front/rear <sup>(6)</sup>	kg	2424/1625	2428/1796	2457/1813	2597/1874	2577/2040	2616/2063
	2.4	Axle loading fork advanced, laden front/rear	kg	891/4758	979/4845	1009/4861	921/5550	985/5632	1024/5655
2.5	Axle loading fork retracted, laden front/rear	kg	2180/3469	2104/3720	2134/3736	2266/4205	2149/4468	2189/4490	
Dimensions	4.19	Overall length	l <sub>1</sub> (mm)	2523	2523	2523	2528	2600	2600
	4.20	Length to face of forks	l <sub>2</sub> (mm)	1373	1373	1373	1378	1450	1450
	4.28	Reach distance	l <sub>4</sub> (mm)	491	491	491	536	464	464
	4.34.1	Aisle width for pallets 1000mm x 1200mm crossways	Ast (mm)	2834	2834	2834	2850	2903	2903
	4.34.2	Aisle width for pallets 800mm x 1200mm lengthways	Ast (mm)	2896	2896	2896	2904	2970	2970
4.35	Turning radius	Wa (mm)	1718	1718	1718	1767	1767	1767	
Electric Engine	6.3	Battery according to DIN 43531/35/36 A, B, C, no	C "Super"	C	C "Super"	C "Super"	C	C "Super"	
	6.4	Battery voltage/nominal capacity K <sub>5</sub>	(V)/(Ah)	48/620	48/700	48/775	48/775	48/840	48/930
	6.5	Battery weight <sup>(4)</sup>	kg	950	1119	1165	1165	1306	1368

Notes - relates to all battery dimensions tables. <sup>(4)</sup> These values may vary of +/- 5%. <sup>(6)</sup> Forks retracted. All weights (2.1 to 2.5) are with lowest mast and standard forks.

# Specifications

## Mast

		1400/1600kg				
Model		MR14, MR16				
Mast Type		3 Stage Full-free Lift				
Manufacturer's type designation	Lift (h <sub>1</sub> ) mm	Free Lift (h <sub>2</sub> ) mm	Height of Mast Lowered (h <sub>3</sub> ) mm	Height of Mast Extended (h <sub>4</sub> ) mm <sup>(1)</sup>	Weight kg <sup>(2)</sup>	
MR16N	5000	1648	2195	5563	911	
	5250	1734	2281	5813	936	
	5500	1820	2367	6063	961	
	5750	1906	2453	6313	986	
	6000	1992	2539	6563	1010	
	6250	2078	2625	6813	1035	
	6500	2164	2711	7063	1060	
	6750	2250	2797	7313	1090	
	7000	2336	2883	7563	1115	
	7250	2422	2969	7813	1140	
	7500	2508	3055	8063	1164	
	7750	2594	3141	8313	1220	
	8000	2680	3227	8563	1244	
	8250	2766	3313	8813	1269	
	8500	2852	3399	9063	1299	
	8750	2938	3485	9313	1324	
	9000	3024	3571	9563	1349	
	9250	3110	3657	9813	1376	
	9500	3196	3743	10063	1400	
	9750	3282	3829	10313	1425	
10000	3368	3915	10563	1454		
10250	3454	4001	10813	1478		
10500	3540	4087	11063	1503		

<sup>(1)</sup> With load backrest h4 + 508mm.

<sup>(2)</sup> All weights are: mast structures (weldment, cylinders, chain, pulley) + carriage + load backrest + oil. Excluded: forks, accessories.

		1600kg				
Model		MR16HD				
Mast Type		Heavy Duty 3 Stage Full-free Lift				
Manufacturer's type designation	Lift (h <sub>1</sub> ) mm	Free Lift (h <sub>2</sub> ) mm	Height of Mast Lowered (h <sub>3</sub> ) mm	Height of Mast Extended (h <sub>4</sub> ) mm <sup>(1)</sup>	Weight kg <sup>(2)</sup>	
	7900	2680	3227	8463	1376	
	8150	2766	3313	8713	1404	
	8400	2852	3399	8963	1438	
	8650	2938	3485	9213	1466	
	8900	3024	3571	9463	1495	
	9150	3110	3657	9713	1524	
	9400	3196	3743	9963	1552	
	9650	3282	3839	10213	1580	
	9900	3368	3925	10463	1612	
	10150	3454	4011	10713	1641	
	10400	3540	4097	10963	1699	
	10650	3626	4183	11213	1728	
	10900	3712	4269	11463	1756	
	11150	3798	4355	11713	1785	
	11400	3884	4441	11963	1813	

<sup>(1)</sup> With load backrest h4 + 508mm.

<sup>(2)</sup> All weights are: mast structures (weldment, cylinders, chain, pulley) + carriage + load backrest + oil. Excluded: forks, accessories.

		2000/2500kg				
Model		MR20, MR25				
Mast Type		3 Stage Full-free Lift				
Manufacturer's type designation	Lift (h <sub>1</sub> ) mm	Free Lift (h <sub>2</sub> ) mm	Height of Mast Lowered (h <sub>3</sub> ) mm	Height of Mast Extended (h <sub>4</sub> ) mm <sup>(1)</sup>	Weight kg <sup>(2)</sup>	
	4650	1582	2195	5263	958	
	4900	1668	2281	5513	985	
	5150	1754	2367	5763	1012	
	5400	1840	2453	6013	1038	
	5650	1926	2539	6263	1065	
	5900	2012	2625	6513	1092	
	6150	2098	2711	6763	1118	
	6400	2184	2797	7013	1150	
	6650	2270	2883	7263	1177	
	6900	2356	2969	7513	1204	
	7150	2442	3055	7763	1230	
	7400	2528	3141	8013	1288	
	7650	2614	3227	8263	1314	
	7900	2700	3313	8513	1341	
	8150	2786	3399	8763	1373	

<sup>(1)</sup> With load backrest h4 + 443mm.

<sup>(2)</sup> All weights are: mast structures (weldment, cylinders, chain, pulley) + carriage + load backrest + oil. Excluded: forks, accessories.

		2000kg				
Model		MR20HD				
Mast Type		Heavy Duty 3 Stage Full-free Lift				
Manufacturer's type designation	Lift (h <sub>1</sub> ) mm	Free Lift (h <sub>2</sub> ) mm	Height of Mast Lowered (h <sub>3</sub> ) mm	Height of Mast Extended (h <sub>4</sub> ) mm <sup>(1)</sup>	Weight kg <sup>(2)</sup>	
	7750	2614	3227	8363	1402	
	8000	2700	3313	8613	1431	
	8250	2786	3399	8863	1465	
	8500	2872	3485	9113	1494	
	8750	2958	3571	9363	1523	
	9000	3044	3657	9613	1552	
	9250	3130	3743	9863	1581	
	9500	3216	3839	10113	1609	
	9750	3302	3925	10363	1638	
	10000	3388	4011	10613	1671	
	10250	3474	4097	10863	1729	
	10500	3560	4183	11113	1758	
	10750	3646	4269	11363	1787	
	11000	3732	4355	11613	1816	
	11250	3818	4441	11863	1844	
	11500	3904	4527	12113	1873	
	11750	3990	4613	12363	1902	
	12000	4076	4699	12613	1931	
	12250	4162	4785	12863	1959	
	12500	4248	4871	13113	1988	

<sup>(1)</sup> With load backrest h4 + 443mm.

<sup>(2)</sup> All weights are: mast structures (weldment, cylinders, chain, pulley) + carriage + load backrest + oil. Excluded: forks, accessories.

# Standard Features & Options

## Standard

### Operator Compartment

- Intermediate step
- Grab handle on overhead guard post
- Grab handle under armrest
- AccuTouch mini-levers mounted on adjustable length armrest
- Full suspension seat – 60mm suspension travel – cloth upholstery
- Standard display
- Adjustable steering column
- Automatic park brake Yalestop
- 180° steering

### Travel Performance

- Travel speed 11km/h (MR14/15 only)
- Travel speed 14km/h with electric load wheel braking (MR20/25, MR16HD, MR20HD only)
- Speed slow down mast reached forward
- Speed slow down on cornering
- Speed slow down over free list

### Lift performance/driver assist

- 3 stage mast/tilting carriage
- Simultaneous lift/reach functionality
- Mast positioning over free lift/main lift sections – fixed sensor mounting\*
- Lift Comfort Package (MR16HD, MR20HD only)
- Lift Performance Package (MR16HD, MR20HD only)

### Application Environment

- Top/front load wheel protection

### Chassis

- Chassis width (max)
  - 1265mm (MR14, MR16, MR16HD, MR20 only)  
*Not available on MR16, MR25, MR20HD*
  - 1125mm (MR16N only)  
*Not available on MR14, MR16, MR20, MR25, MR16HD, MR20HD*
  - 1345mm (MR25 only)  
*Not available on MR14, MR16, MR16N, MR20, MR16HD*

### Standard Warranty

- Truck 12 months (2000 hours)
- Powertrain 24 months (4000 hours)

## Options

### Operator Compartment

- Joystick mounted on adjustable length armrest
- Full suspension seat – 80mm suspension travel – cloth upholstery
- Head rest (cloth version only)
- Synchronised seat cushion and back rest movement (cloth version only)
- Heated seat
- Antistatic seat (cloth version only)
- Vinyl seat upholstery
- Premium display with touch screen
- Keyless access

- 360° steering
- Driver select steering mode 180/360° (push button)

### Lift performance/driver assist

- Simultaneous hydraulic functionality – 3 functions
- Lift Comfort Package<sup>(1)</sup>
- Lift Performance Package
- Laser line fork positioning aid (above free lift)
- Auto side shift centering
- Auto fork levelling in the horizontal position
- Height preselector (with/without pallet detection device)
- Fork mounted camera/monitor
- Load weight indicator

### Application Environment

- 5th hydraulic function
- Universal support bracket
- Beverage holder and document tray
- A4 clipboard
- Stretch film roll holder
- Lift limit with override (1 x height setting)
- Lift limit with override (2 x height setting)
- Lower limit (with override option)
- Flashing beacon
- Work lights x 2 (mast side) x 1 (drive side)
- Polycarbonate (lexan) protection on overhead guard
- Metal grid protection on overhead guard
- Side load wheel protection
- High temperature environment
- Side battery change – rollers
- Side battery change – tray
- Extension cable
- Drive-in overhead guard (w 930 x h 1400 / w 930 x h 1700mm)
- Anti-static drive and load wheels
- Wet surface drive and load wheels
- Side guidance rollers
- DC/DC converter (choice of 12V/48V, 24V/48V, 12-24V/48V options)
- Audible alarm (choice of fork leading, forks trailing, both travel directions)
- Load backrest (choice of heights 1000/1500mm)
- Extendable forks - double deep option
- Speed reduction to 3km/h with forks raised
- Cold store cabin

### Chassis/Battery Sizes

- Chassis width (max)
  - 1345mm (MR20HD only)
- Battery sizes<sup>(2)</sup>
  - 420-465Ah (MR14, MR16, MR16N only)  
*Not available on MR20, MR25, MR16HD, MR20HD*
  - 560-620Ah (MR14, MR16, MR16N, MR20, MR16HD only)  
*Not available on MR25, MR20HD*
  - 700-775Ah (MR14, MR16, MR16N, MR20, MR25, MR16HD, MR20HD only)
  - 840-930Ah (MR25, MR20HD only)  
*Not available on MR14, MR16, MR16N, MR20, MR16HD*

\*Not available on MR20HD

<sup>(1)</sup> Includes: End of stroke slow down on lift, Soft stop on lowering, Height controlled mast cushioning over Free Lift/Main Lift mast section, Height indicator

<sup>(2)</sup> DIN C Battery on MR14/MR16/MR20/MR25/MR16HD/MR20HD, DIN B Battery on MR16N

# Yale® Dealers

Contact your nearest  
Yale® Dealership by visiting  
[www.yale.com](http://www.yale.com)



Contact your local Yale® Dealer

 Safety. This truck conforms to the current EU requirements. Specification is subject to change without notice.



#### Yale Asia Pacific

Address: 1 Bullecourt Ave, Milperra NSW 2214

Phone: (02) 9795 3800 | Fax: (02) 9795 3801

[www.yale.com](http://www.yale.com)

Yale is a registered trademark. *People. Products. Productivity.* is a trademark in the United States and certain other jurisdictions.  is a registered copyright of Yale Materials Handling Corporation. © Yale Asia Pacific 2013. All rights reserved. Printed in Australia.

Specifications and details in this brochure are subject to change without prior notification.

[www.yale.com](http://www.yale.com)



/Yaleasiapacific



@Yale\_AP

**Yale**<sup>®</sup>   
*People. Products. Productivity.™*